



**PEV<sup>®</sup>**

Electronic force gauge  
for loads from 200 to 32,000 kg

 **VERLINDE**  
LIFTING EQUIPMENT

# PEV<sup>®</sup>

## Electronic force gauge for loads from 200 to 32,000 kg

Electronic force gauge for loads from 200 to 32 tons for intensive use in lifting and handling systems (for hoists, mobile cranes, posts and aerial handling systems).

Real time display by LED or LCD (according to model) on large format screen. A stainless steel version is available for agricultural-food applications.

The equipment is delivered with two galvanised lifting lugs, an upper ring and a lower hook, in addition to sealed, rechargeable batteries and charger.



### ► Technical characteristics

- > Ultra-portable equipment.
- > Very strong steel construction to protect against impacts, dual component epoxy paintwork.
- > Protection against overvoltages.
- > Lexan control keypad for improved comfort during use.
- > Large format LCD or LED display for improved legibility.
- > 2 galvanised lifting points as standard.
- > Extensive range of options for optimal weighing matching your requirements and environment (built in printer, stainless steel version, Bluetooth or WiFi connection).
- > +/- 0.01% accuracy for nominal capacity.
- > Operating temperature: -20 °C to + 60 °C.
- > Protection: IP 55.



PEV3



PEV2



PEV1



Remote control

Radio link



### Product advantages

	PEV 1	PEV 2	PEV 3
> Overload signal (110% of lax load)	●	●	●
> Battery low signal	●	●	●
> Tare	●	●	●
> Return to zero	●	●	●
> Total amount	○	●	●
> Total deletion	○	○	●
> Excellent legibility on large display (LCD or LED)	5 LCD 30/48 mm	5 LCD 25,4 mm	5 LCD 45,72 mm
> Value recording maximum value	○	○	○

### Options available

	PEV 1	PEV 2	PEV 3
> 5 LED 35.4 mm display		●	
> Infra-red remote control (functions M+, RM, MO, tare, total amount, on/off)	●		
> Carrying case (up to model 5T)	●	●	●
> Load preselection (standard with IR control)		●	
> Two sets of batteries for intensive use		●	●
> Stainless steel version		●	●
> Tropical weather and IP 65		●	●
> Built-in printing machine			●
> Bluetooth or WiFi connection		NC	NC
> Display	●	●	●

● : serial ○ : optional



Carrying case

Built-in printing machine



# PEV<sup>®</sup>

## Electronic force gauge for loads from 200 to 32,000 kg

### ► Technical characteristics & dimensions

Capacity (kg)	Scale (kg)	Dimensions				Total weight (kg)	
		L1	L2	L3	L4	with accessory	without accessory
500	0.2	134	244	504	379	3.5	5.2
1,000	0.5	134	244	549	399	3.5	6.2
2,000	1	134	244	549	399	3.5	6.2
3,200	1	146	336	706	526	4.5	8.2
5,000	2	160	350	720	540	5.9	10.5
6,300	2	160	350	720	594	5.9	16.5
10,000	5	174	449	949	724	7.2	24

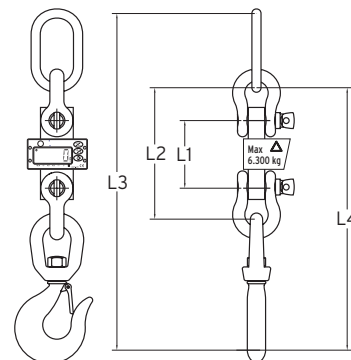

Capacity (kg)	Scale (kg)	Dimensions				Total weight (kg)	
		L1	L2	L3	L4	with accessory	without accessory
500	0.2	134	244	504	379	3.5	5.2
1,000	0.5	134	244	549	399	3.5	6.2
2,000	1	134	244	549	399	3.5	6.2
3,200	1	146	336	706	526	4.5	8.2
5,000	2	160	350	720	540	5.9	10.5
6,300	2	160	350	720	594	5.9	16.5
10,000	5	174	449	949	724	7.2	24

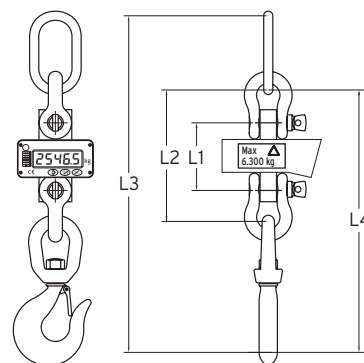

Capacity (kg)	Scale (kg)	Dimensions				Total weight (kg)	
		L1	L2	L3	L4	with accessory	without accessory
500	0.2	134	244	504	379	3.5	5.2
1,000	0.5	134	244	549	399	3.5	6.2
2,000	1	134	244	549	399	3.5	6.2
3,200	1	146	336	706	526	4.5	8.2
5,000	2	160	350	720	540	5.9	10.5
6,300	2	160	350	720	594	5.9	16.5
10,000	5	174	449	949	724	7.2	24
12,000	5	205	449	1027	773	14	33.4
16,000	10	209	508	1168	863	17	49.2
25,000	10	240	605	1434	1085	24	82.8
35,000	20	270	676	1608	1202	31	117.7

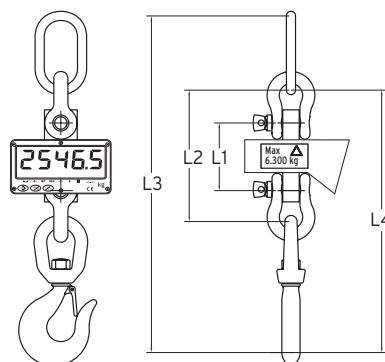

2, boulevard de l'Industrie - B.P. 20059 - 28509 Vernouillet cedex - France

Phone : (33) 02 37 38 95 95 - Fax : (33) 02 37 38 95 99

Internet : [www.verlinde.com](http://www.verlinde.com)