



# EUROBLOC VM

## > ESSENTIAL

Electric wire rope hoist and crane kit  
with load from 2,000 to 20,000 kg

Ref : 06 2016 336 GB

# EUROBLOC VM

## >ESSENTIAL

## Electric wire rope hoist and crane kit with load from 2,000 to 20,000 kg

### >Safety

- Electro mechanical load limiter deliver as standard (Mandatory equipment according "Machinery" directive).
- Hoisting limit switch.
- 2 travelling speed.
- Galvanized wire rope, high safety factor (Coef. 4,6 in 2m group).
- 2 step travelling limit switch.
- IP 55 protection on electric cubicle, oversize dimensions to place and protect all components.
- Low voltage control (48 V) for higher safety.
- Rotating hook with safety latch.
- Complete documentation pack (hoist test certificate, hook and wire rope certificate, electric diagram, CE certificate).

### >Savings (use/maintenance)

- 2 travelling and hoisting speed to optimize your production process.
- Lifting brake designed for hoist unit lifetime in normal use.
- Lifetime lubricated lifting gear box.
- Electric cubicle offer easy access and optimize opening for maintenance operation. Cable entry are operate by plug in connector under the cubicle.
- Lifetime lubricated travelling gear box.

- Rope guide built "without spring" so that it can be more easily replaced during maintenance.
- Very high performance for difficult environments.
- Modular assembly concept to reduce number of spare parts.
- Surface treatment. 2 components epoxy paint with 120 µ for greater protection.
- Hoisting motor. 60 % operating factor and tropicalized as a standard for greater longevity.
- Bearing of hook and hook block are lifetime lubricated. Pulley made from GGG cast iron.
- A very high wire rope / drum diameter ratio which increases the longevity of the wire rope.
- Control by pendant or radio emitter.

### >Hoist conception

- Reduces the approach data of the hoist.
- Reduces the "C" approach data of the hook. Reduce lateral motion of the hook when lifting.
- Optimal positioning of steering rollers to share the load in order to optimize your tracks.
- Available only in low headroom trolley and double girder trolley construction.

### >The range

SWL (kg)	EUROBLOC VM Essential	Group		Height of lift (m)	Hoisting speed (m/min)	Gauge	Travelling speed (m/min)	Travelling trolley	
		ISO	FEM					HPR	Double girder
2000	VM104115...AFP1	5	2m	6	5/0,8	1200	20/5	•	•
2000	VM104115...CFP1	5	2m	9,5	5/0,8	1200	20/5	•	•
2500	VM104116...AFP2	6	3m	6	5/0,8	1200	20/5	•	•
2500	VM104116...CFP2	6	3m	9,5	5/0,8	1200	20/5	•	•
3200	VM104115...AFP2	5	2m	6	5/0,8	1200	20/5	•	•
3200	VM104115...CFP2	5	2m	9,5	5/0,8	1200	20/5	•	•
4000	VM204116...BFP3	6	3m	6	5/0,8	1200	20/5	•	•
4000	VM204116...CFP3	6	3m	9	5/0,8	1200	20/5	•	•
5000	VM204115...BFP3	5	2m	6	5/0,8	1200	20/5	•	•
5000	VM204115...CFP3	5	2m	9	5/0,8	1200	20/5	•	•
6300	VM204114...BEP3	4	1Am	6	4/0,7	1200	20/5	•	•
6300	VM204114...CEP3	4	1Am	9	4/0,7	1200	20/5	•	•
8000	VM304116...EFP5	6	3m	9	5/0,8	1400	20/5	•	•
8000	VM304116R...EFP5	6	3m	12	5/0,8	1400	20/5	•	•
10000	VM304115...DFP5	5	2m	9	5/0,8	1400	20/5	•	•
10000	VM304115...EFP5	5	2m	12	5/0,8	1400	20/5	•	•
12000	VM306116...FFP5	6	3m	10	3,2/0,5	2000	24/6	•	•
12000	VM306116...GFP5	6	3m	13	3,2/0,5	2400	24/6	•	•
12500	VM304114...DEP5	4	1Am	9	4/0,7	1400	20/5	•	•
12500	VM304114...EEP5	4	1Am	12	4/0,7	1400	20/5	•	•
15000	VM306115...FFP5	5	2m	10	3,2/0,5	2000	24/6	•	•
15000	VM306115...GFP5	5	2m	13	3,2/0,5	2400	24/6	•	•
16000	VM308115...FFP5	5	2m	8	2,5/0,4	2000	24/6	•	•
16000	VM308115...GFP5	5	2m	10	2,5/0,4	2400	24/6	•	•
20000	VM308114...FFP5	4	1Am	8	2,5/0,4	2000	24/6	•	•
20000	VM308114...GFP5	4	1Am	10	2,5/0,4	2400	24/6	•	•



### >Options available

- Back-up pendant (non movable) in case of radio failure.
- DIGIMOTE Radio instead of radio remote ESSENTIAL.
- Derailment catches (double girder trolley).
- Hook operated limit switch HS22 (Manual reset).
- Light and horn for overload indication (98 dB or 108 dB).
- Trolley limit switch 2-step (slow+stop).



- Crash protection with photo cell (1 set).
- Indicator beacon for crane (radio in use).
- Horn 98 dB or 108 dB.
- Spare transmitter for DIGIMOTE.
- Radio Battery & charger set for Tele Radio.
- Provision for radio control.
- Back-up pendant attached to crane control panel.
- Pendant attached to hoist.
- Pendant magnet.
- Derailment catches (crane end carriage).
- Buffer extensions for crane end carriage (100, 200, 250, 300, 400, 500, 600, 700, 800, 900, 1000 mm).
- End carriages epoxy painted.

# COMPOSANTS + >ESSENTIAL

DIGIMOTE remote control  
in option.

# COMPOSANTS +

## >ESSENTIAL

Standard kit for single and double girder top running crane.  
Load from 2,000 to 20,000 kg

Electric wire rope hoist EUROBLOC ESSENTIAL is available too with complete kit COMPOSANTS+ ESSENTIAL. You will discover here under kit contents :

### 1 Electric wire rope hoist (EUROBLOC VM ESSENTIAL).

- Load range : 2000 to 20,000 kg.
- Height of lift : 6, 9 or 9,5 m (VM1, VM2) and 8, 9, 10, 12 or 13 m (VM3).
- Reeving : 4 or 8 falls.
- Dual speed hoist motor with 6:1 speed ratio.
- Dual speed trolley travel via contactors with 4:1 speed ratio.
- Short headroom trolley and double girder trolley only.
- 2 step travelling limit switch.
- Top and low hoisting limit of hook activated by gear limit switch in gear box.
- Overload limiter as standard.
- Electric equipment for crane kit.
- EUROBLOC VM ESSENTIAL offer clear benefits in term of compact dimensions and C dimension.

### 2 Travelling End carriages for top running crane.

- Direct drive wheels.
- 2 Rubber buffer per end carriages.
- The end-carriages are fastened with a plate bolted onto the girder (box and profile girders).
- Variable speed.
- 2 steps crossing limit switches.
- Thermal protection on crossing motor.
- Derailment protection devices.
- New optimized crane layout : with new location drive bridge/crane panel/radio receiver, with a reduced amount of parts.
- Energy chain : 50% less screw for fixing.

### 3 Crane control panel.

- Compact design, using proven components from standard crane kit.
- Mounted on end-carriage, height adjustable for optimal building fit in the crane.
- No significant impact on trolley end approach dimension.
- Easy attachment of radio receiver by magnets.
- Optional pug-in control pendant for emergency operation.
- IP 55 Protection on steel electric cubicle, indoor use.

### 4 Energy chain.

- Energy chain deliver as standard: Fast & easy installation in crane factory : number of bolts reduced by 50 %.
- Cutting threads to profile girders not required.
- Welding option on box girders.
- Clean and modern appearance of crane, no cables loops.
- Less wearing parts. Cables protected against mechanical damages.

### 5 Radio remote control ESSENTIAL.

- This system have been specially designed to operate with components from COMPOSANTS+ ESSENTIAL and electric wire rope hoist EUROBLOC VM ESSENTIAL.
- 6 motions : up, down, travelling, crossing, emergency button.
- Klaxon (98 dB as standard and 108 dB as option).
- Backup transmitter of Radio remote control ESSENTIAL included with standard delivery of the crane kit.
- One set of batteries is deliver as standard in the crane kit.
- Receiver located on the electric cubicle, fixation with magnets.
- Set of stickers for emitter to adapt marking at local regulation (DIN, FIN, ANSI).
- Easy operating procedure, high reliability.
- Increase operator productivity and safety during load lifting operation.
- Optional\* : DIGIMOTE radio controls for certain countries and applications.

\*In this case 1 transmitter is included with standard delivery of the crane kit.





High wire rope/drum diameter ratio.

Travelling Motor/gear box : 2 speeds.  
2 steps travelling limit switch.

Hoisting Motor :  
2 speeds.

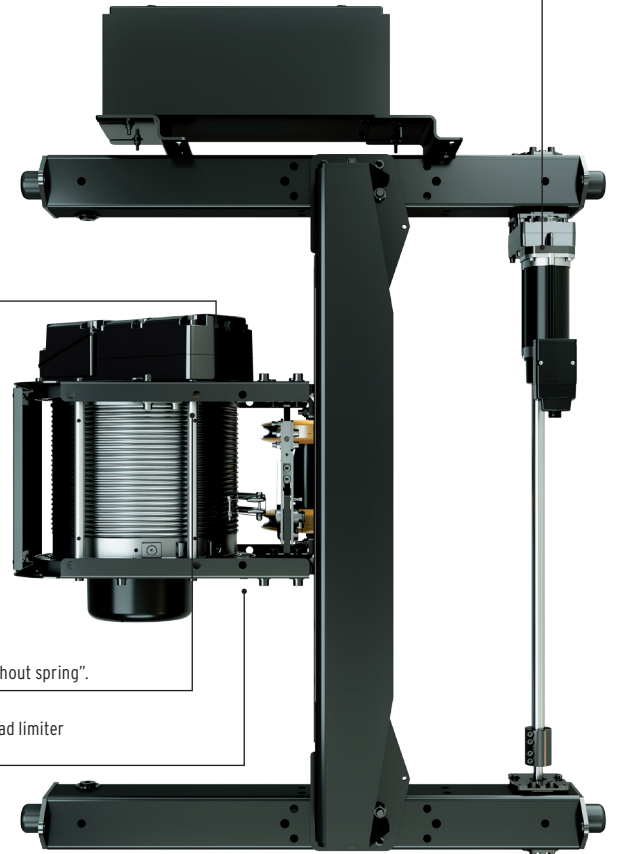

Rope guide built "without spring".

Electro mecaanical load limiter  
deliver as standard.

# EUROBLOC VM1 ESSENTIAL

## >Technicals datas

- Power supply : 400 V/3 ph/50 Hz.
- Control voltage : 48 V.
- Working temperatures : +5 °C to +40 °C.

## >Options available

- Lifting limit switch activate by hook block.
- Overload indication by lighting or audible signal.

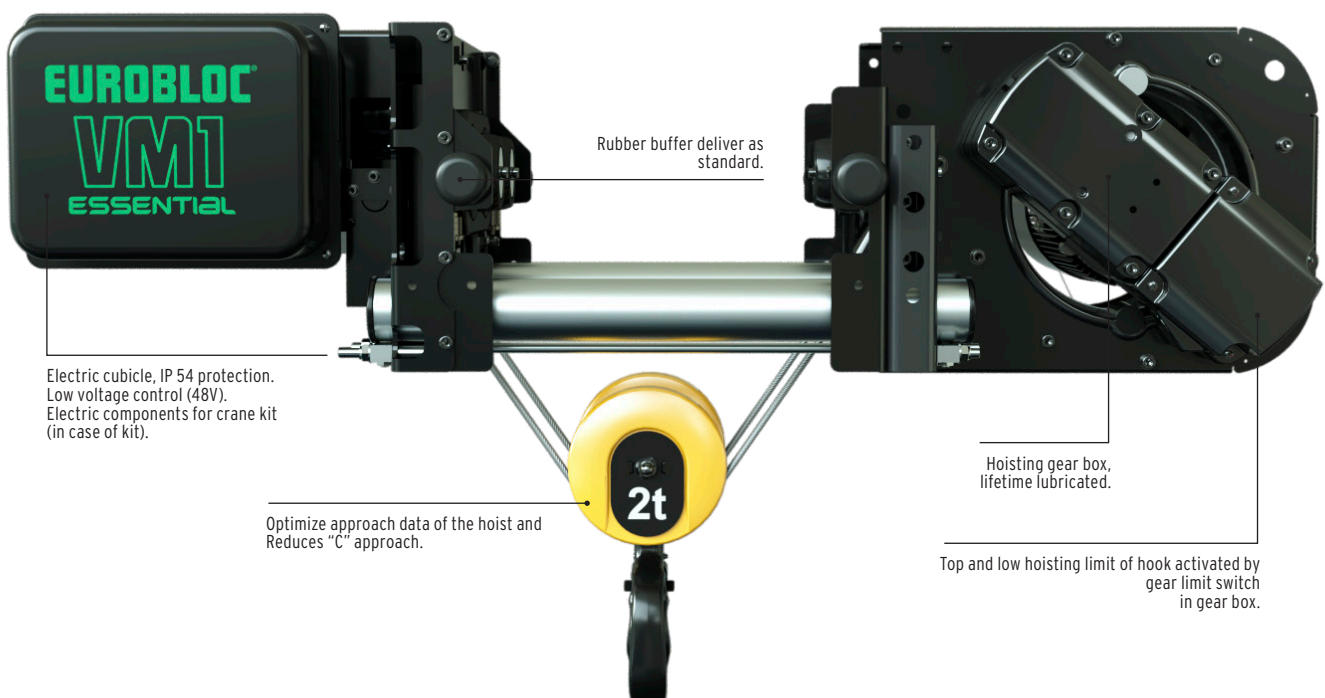

Rubber buffer deliver as standard.

Electric cubicle, IP 54 protection.  
Low voltage control (48V).  
Electric components for crane kit  
(in case of kit).

Optimize approach data of the hoist and  
Reduces "C" approach.

Hoisting gear box,  
lifetime lubricated.

Top and low hoisting limit of hook activated by  
gear limit switch in gear box.



## VERLINDE is :

- The leading French manufacturer and exporter of lifting and handling equipment.
- A comprehensive range of 30 groups of lifting equipment from 60 to 250,000 kg.
- ISO 9001 Quality control certified and ISO 14001 Environmental Management Systems.



## Our references

**Metallurgy, Mechanics, Nuclear** ➤ ArcelorMittal - Unimetal - Stein - NFM - Framatome - Alstom

**Chemicals, Petrochemicals industry** ➤ Sanofi Aventis - Du Pont De Nemours - Total

**Aeronautical industry** ➤ Aérospatiale - Airbus - Eurocopter - Air France - Aéroport de Paris - Snecma - Dassault Aviation

**Agri-food industry** ➤ Nestlé - Danone - Bel - Palamatic - Tetrapak - Lactalis

**Automobile industry** ➤ Renault - Peugeot - Citroën - Scania - Ford - RVI - Volkswagen - Michelin - Massey Ferguson - Manitou - Toyota Industrial Equipment

**Other sectors** ➤ EDF - SNCF - RATP - Spie - Degremont - Eiffage - Polysius - Baudin Chateaufort



## In France :

A sales network and after sales service points, EUROPOINT travelling crane construction plants and a distributor network.

## Abroad :

A specialized partner in more than 92 countries.



2, boulevard de l'Industrie - B.P. 20059 - 28509 Vernouillet cedex - France  
Telephone : (33) 02 37 38 95 95 - Fax : (33) 02 37 38 95 99  
Internet : [www.verlinde.com](http://www.verlinde.com)