



# CHD<sup>®</sup> & CHDD<sup>®</sup>

Manual travel trolleys  
for loads from  
250 to 20,000 kg

 **VERLINDE**  
LIFTING EQUIPMENT

# CHD-CHDD®



**CHD®**  
Manual push trolley  
operated by push action  
on load.

Manual travel  
trolleys for  
loads from  
250 to 20,000 kg



**CHDD®**  
Travel trolley operated by  
hand wheel and hand chain.

## ► Load Capacity

	250 kg	500 kg	1000 kg	2000 kg	3000 kg	5000 kg	6300 kg	7500 kg	10000 kg	12500 kg	16000 kg	20000 kg
> CHD												
> CHDD												

The VERLINDE Technologies catalogue with our range of explosion-proof products is also available.

► Technical characteristics

- > Can be used with any type of overhead hooked lifting device.
- > Operated by directly pushing the load (CHD models) or using a handwheel and chain (CHDD models).
- > Delivered in individual boxes, ready to assemble.
- > Easily adjustable to fit up to 300mm beams (over 300mm on request).
- > Trolley flange made of heavy-duty steel.
- > Side plates finished with RAL7021 powder coating, 70 µ thick.
- > Rollers machined for smooth movement.
- > Rollers compatible with all sorts of I and H beams.
- > Watertight, maintenance-free ball bearings.
- > Galvanized hand chain.
- > Fall-prevention brackets and rubber stops.
- > Loads up to 20 tons (higher capacity possible on demand).
- > Serial number inscribed on chassis.



**CHD**

EX-ATEX manual push trolley operated by push action on load.

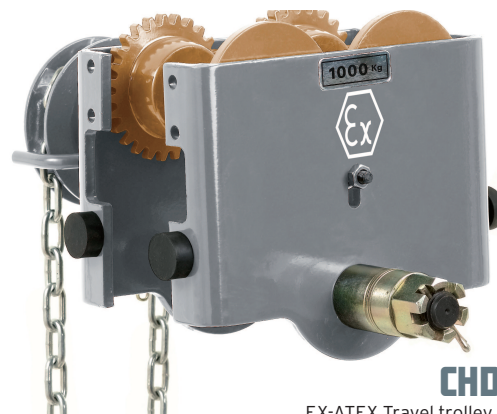

**CHDD**

EX-ATEX Travel trolley operated by hand wheel and hand chain.

► Options

- > Stainless steel hand chain.
- > Ex Version with ATEX markings.

Load	T		A		C	D	E	F	G	H	J	K	L	M	P	O*	U	Min curve radius (m)	Trolley weight CHD (kg)		Trolley weight CHDD (kg)	
	Range 1	Range 2	Range 1	Range 2															Range 1	Range 2	Range 1	Range 2
<b>250 kg</b>	50-202	-	278	-	32	60	12.5	170	80	190	15	50	62	30	99	-	19	1.0	3,5	-	-	-
<b>500 kg</b>	50-202	188-310	303	411	32	62	17	186	84	210	20	55	67	34	106	-	19	1.0	8	10	-	-
<b>1000 kg</b>	65-202	188-310	316	424	39	81	20	225	101	242	24	60	76	38	135	146	24	1.5	12	14	14	16
<b>2000 kg</b>	88-202	188-310	340	448	42	96	22	272	116	296	30	76	92	38	159	146	27	2.0	20	22	22	24
<b>3000 kg</b>	100-202	188-310	356	464	49	140	25	322	144	346	28	96	114	42	192	38	32	2.0	38	40	42	44
<b>5000 kg</b>	114-202	188-310	375	483	60	161	28	360	158	384	35	108	126	42	214	38	48	3.0	59	61	63	65
<b>7500 kg</b>	124-202	188-310	394	502	68	176	38	415	185	439	43	130	150	45	247	68	45	3.0	100	103	104	107
<b>10000 kg</b>	124-202	188-310	400	508	70	187	39	434	200	458	50	132	155	46	265	67	49	3.0	116	119	120	123
<b>12500 kg</b>	124-202	188-310	358	464	70	187	39	442	200	466	50	134	155	45	265	64	50	3.0	121	126	125	130
<b>16000 kg</b>	136-202	188-310	416	522	92	283	51	555	272	579	64	168	197	64	390	78	77	3.5	211	216	215	220
<b>20000 kg</b>	136-202	188-310	449	551	88	278	-	555	272	579	68	175	-	60	-	78	77	3.5	216	222	220	228

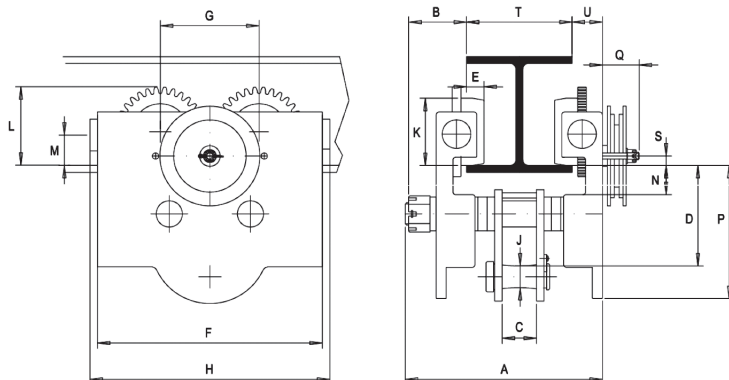

\* This dimension is given only for travel trolley operated by hand wheel and hand chain.



## VERLINDE is :

- The leading French manufacturer and exporter of lifting and handling equipment.
- A comprehensive range of 30 groups of lifting equipment from 60 to 250,000 kg.
- ISO 9001 Quality control certified.



## Our references

**Metallurgical, Mechanical, Nuclear industries** → ArcelorMittal - Unimetal - Stein - NFM - Framatome - Alstom

**Chemical and Petrochemical industries** → Sanofi Aventis - Du Pont De Nemours - Total

**Aeronautics industry** → Aérospatiale - Airbus - Eurocopter - Air France - Aéroport de Paris - Snecma - Dassault Aviation

**Agri-food industry** → Nestlé - Danone - Bel

**Automobile industry** → Renault - Peugeot - Citroën - Scania - Ford - RVI - Volkswagen - Michelin - Massey Ferguson - Manitou - Toyota Industrial Equipment

**Other sectors** → EDF - SNCF - RATP - Spie - Degremont - Eiffage - Polysius - Baudin Chateaufort



## In France :

A sales network and after sales service points, EUROPONT travelling crane construction plants and a distributor network.

## Rest of world :

A customer service in more than 55 countries.



2, boulevard de l'Industrie - B.P. 20059 - 28509 Vernouillet cedex - France

Phone : (33) 02 37 38 95 95 - Fax : (33) 02 37 38 95 99

Internet : [www.verlinde.com](http://www.verlinde.com)